

NECLASIFICAT

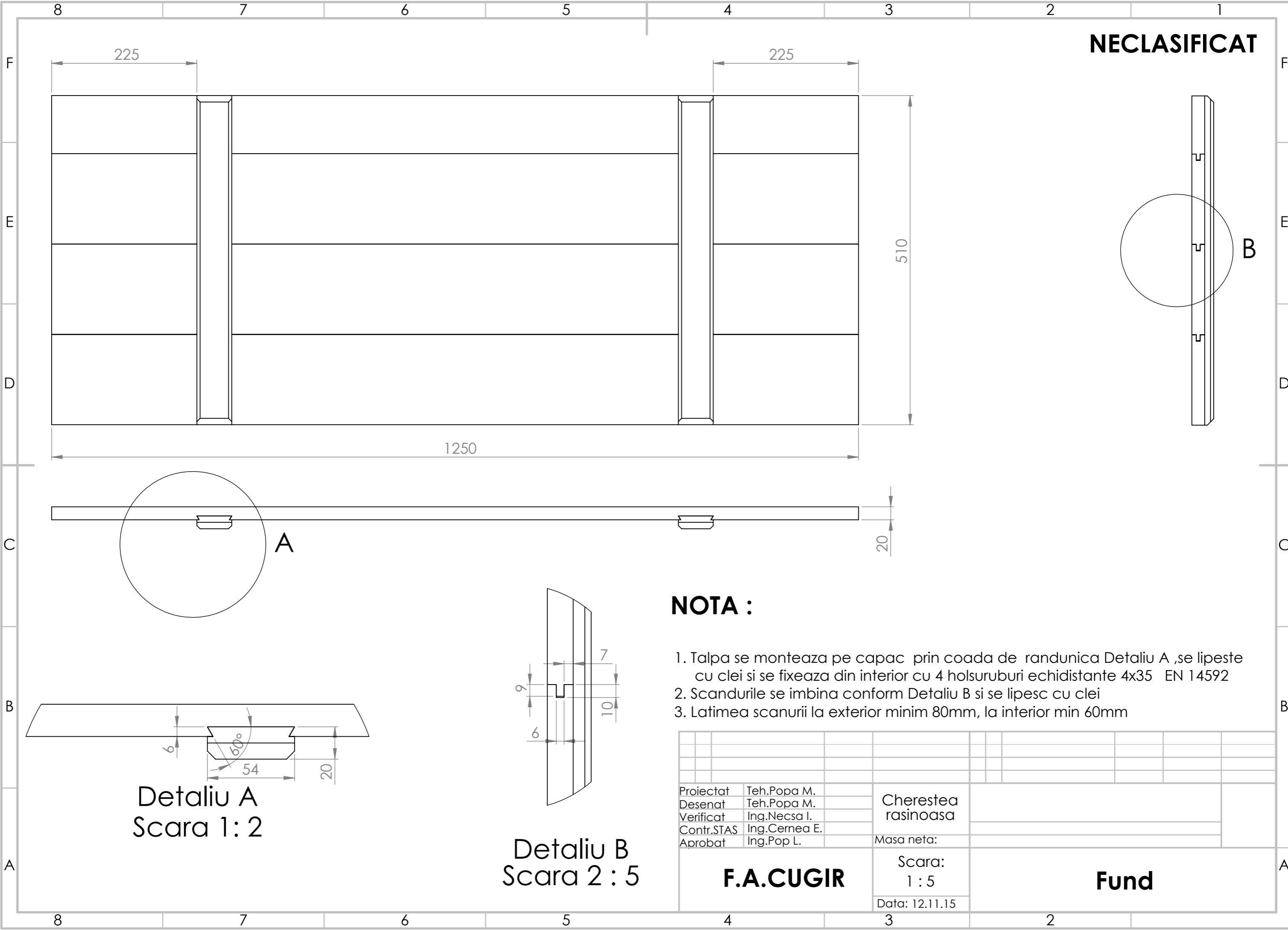

Detaliu A
Scara 1 : 2

Detaliu B
Scara 2 : 5

NOTA :

1. Talpa se monteaza pe capac prin coada de randunica Detaliu A ,se lipeste cu clei si se fixeaza din interior cu 4 holsuruburi echidistante 4x35 EN 14592
2. Scandurile se imbrina conform Detaliu B si se lipeste cu clei
3. Latimea scanurii la exterior minim 80mm, la interior min 60mm

| | | | |
|------------------|---------------|---------------------|------------|
| Proiectat | Teh.Popa M. | Cherestea rasinoasa | Masa neta: |
| Desenat | Teh.Popa M. | | |
| Verificat | Ing.Necsa I. | Scara: 1 : 5 | Fund |
| Contr.STAS | Ing.Cernea E. | | |
| Aprobat | Ing.Pop L. | Data: 12.11.15 | |
| F.A.CUGIR | | | |